

Ultrasonic Stud Welding

In many applications requiring permanent assembly, a continuous weld is not required. Frequently the size and complexity of the parts limit the type of joint design that can be used. With compatible materials, this type of assembly can be effectively and economically accomplished using ultrasonic stud welding, a reliable assembly technique which can be used to join thermoplastic parts at a single point or numerous locations.

This technical information sheet describes ultrasonic stud welding and provides design guidelines for its use.

General Description

Ultrasonic stud welding is the process of joining thermoplastic parts at localized areas, singly or in multiples, by driving a molded stud into a hole with an interference fit, similar to a shear joint.

Mechanics of Operation

The vibrating horn contacts the outer surface of the part over the weld (stud) area, causing a frictional heat buildup to occur at the interface of the stud and socket, melting the thermoplastic material, thus allowing the sections to telescope together. At the end of the weld cycle, the vibrations are stopped, and the parts are held together under pressure allowing the molten material to resolidify.

Stud Welding Joint Design Guidelines

As with any good ultrasonic welding joint, a part designed for stud welding must meet three basic requirements:

- Small initial contact area
- Uniform contact
- Means of alignment

Figure 1 shows the basic stud welding joint before, during, and after welding. Welding occurs along the The radial interference must be uniform and should generally be 0.008 to 0.012 inch (0.2 to 0.3 mm) for

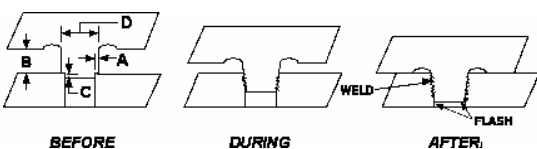

A = 0.008" to 0.012" (0.2 to 0.3 mm) for D up to 0.5" (12.5 mm)
 B = Depth of weld. B = 0.5D for maximum strength (stud to break before joint failure).
 C = 0.020" (0.508 mm) minimum lead-in. The step can be at the end of the pin or the top of the hole.
 D = Stud diameter.

Figure 1.. Ultrasonic Stud Welding Joint

circumference of the stud and socket due to the interference.

studs having a diameter of 0.5 inch (12.5 mm) or less. This also provides the small initial contact area required, which helps reduce the cycle time by concentrating the vibratory energy in a localized area.

The means of alignment is provided by the lead-in which can be on the end of the stud or at the top of the acceptance hole. When using the latter, a small chamfer can be used for rapid alignment.

Other Design Considerations

To reduce stress concentration during welding and in use, an ample fillet radius should be incorporated at the base of the stud. Recessing of the fillet below the surface serves as a flash trap which allows flush contact of the parts.

The resulting strength of the weld is a function of the stud diameter and the depth of weld (i.e., total area). Maximum strength in tension is achieved when the depth of weld equals half the diameter.

When appearance is important, or where an uninterrupted surface is required, welding a stud into a boss is an alternative design. The outside diameter of the boss should be no less than two times the stud diameter. The acceptance hole should be a sufficient distance from the edge to prevent deflection or breakout. A minimum of 0.125 inch (3 mm) is recommended. (See Figure 2.)



Figure 2.. Stud in Boss or Blind Hole

Due to the possible pressure buildup which could result from welding into a blind hole, it may be necessary to provide an outlet for air. Two possibilities can be considered: a center hole through the stud or wall section, or a small narrow keyway in the boss.

Design Variations

The stud welding technique can be used in other ways as illustrated in Figure 3. A third piece of dissimilar material can be locked in place. Example B shows separate molded rivets in lieu of metal self-tapping screws or other fasteners, which unlike metal fasteners produce a relatively stress-free assembly.

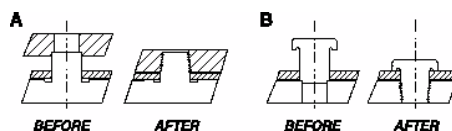

Figure 3.. Variations of Basic Joint

In cases where the size of the part or cycle time requires that the total area being welded be reduced to minimize the energy input, a design using vertical energy directors could be used. (See Figure 4.)

Another way to utilize stud welding would be to use a conical energy director on the end of the stud. (See Figure 5.) Note: Control of dimensional tolerances is important to ensure consistency.

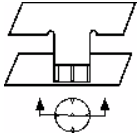

Figure 4.. Stud Weld with Vertical Energy Directors

Stud welding of thin-walled parts (0.060 inch/1.5 mm) or where the amount of relative dimensional change during welding between two parts is limited, such as when locating gears or other internal components, a double-stepped stud should be considered (Figure 6). This reduces movement by 50 percent, while the area and strength of the weld remain the same. With the standard stud joint, the required lead-in reduces the available area and strength.

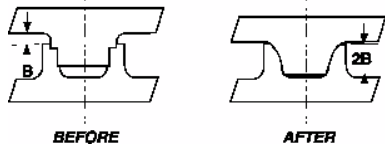
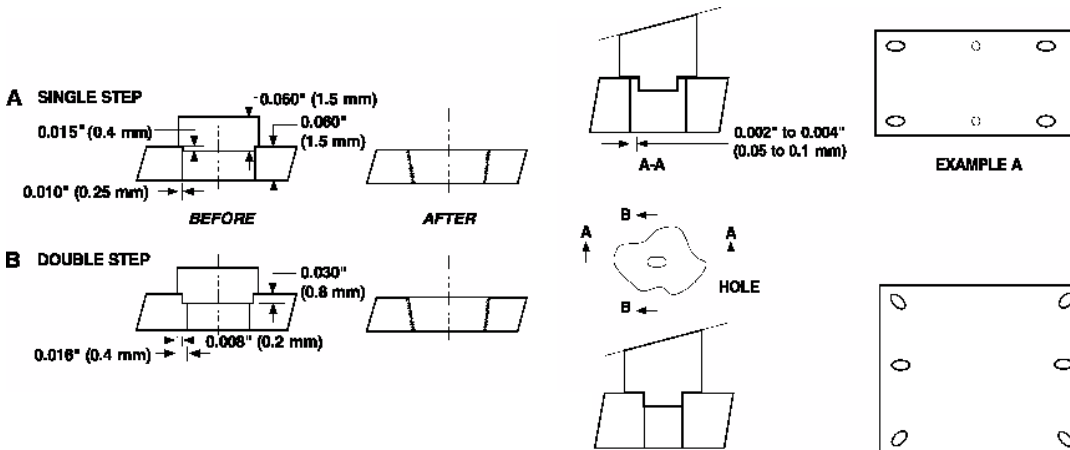

Figure 6.. Double --Stepped Stud Weld

A variation of the stud welding technique employs the use of separate plugs (Figure 7A). When stud welding into thin walls (0.060 inch/1.5 mm) the plugs may be double-stepped (Figure 7B).

- Low pressure, 5-30 psig (35-207 kPa), with the pressure increased accordingly for large areas.
- Slow stroke or downspeed of the carriage assembly to allow melting to occur and prevent coupling of the parts.
- Pretriggering of the horn is also suggested for best results, as it allows fast initial heat build-up.



Horn Requirements for Ultrasonic Stud Welding

Standard horns with no special tip configuration are used. High amplitude horns or horn and booster combinations are generally required. Best results are obtained when the horn contacts the part directly over the stud and on the side closest to the joint (Figure 8).

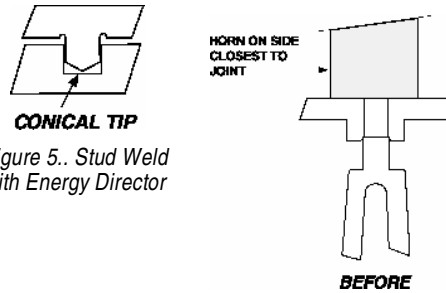

Figure 5.. Stud Weld with Energy Director

Figure 8.. Optimum Horn Location

When welding a number of pins in a single part, one horn can often be used. If the studs are widely spaced (more than 3 inches [76 mm] between furthest studs), small individual horns energized simultaneously should be used. In these cases, variations such as those shown in Figure 9 should be considered.

